

# JPM

## 变频调速永磁同步电动机

### JPM Series Frequency Conversion Speed Control Permanent Magnet Electric Motor

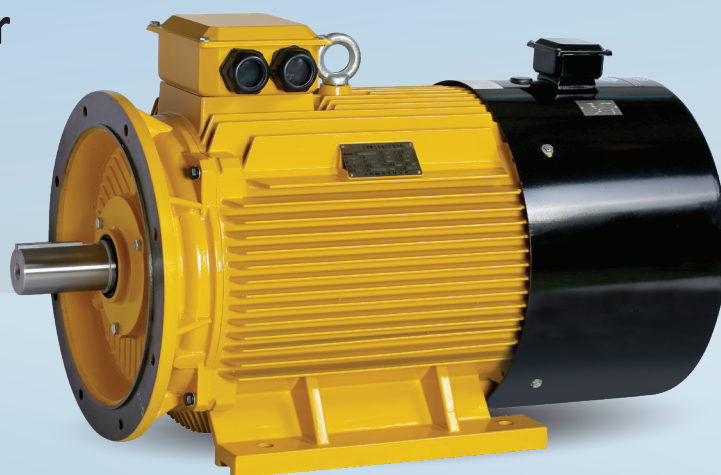

JPM系列电动机,是我司为响应国家节能减排号召,开发的一种是全封闭稀土永磁同步电动机,它具有高过载能力,高效率,高功率因数,运行平稳,维护简单,互换性强等一系列特点,集合了异步电机和一般同步电机的优点,冷却方式IC416/IC411、工作制S1、安装方式符合IEC和DIN标准,具有国际通用性是出口及替代进口的理想产品。

JPM series motor, it is our company to respond to a nation called on energy conservation and emissions reduction, development of one is a fully enclosed of rare earth permanent magnet synchronous motor, with high overload capacity, high efficiency, high power factor, stable operation, simple maintenance, strong interchangeability and a series of features, collection the advantages of the induction motor and synchronous motor cooling IC416 / IC411, duty S1, installation in compliance with IEC and DIN standards, with international generality is ideal and replace the imported products for export.

#### 高效率 High efficiency

永磁同步电机在各个负载区间效率比异步电机高很多,其高效运行范围宽,在25%~120%范围内效率大于90%,永磁电机效率高于能效标准GB30253-2013的一级能效要求,等同IE5能效。

The efficiency of permanent magnet synchronous motor is much higher than that of asynchronous motor in each load interval. Its efficient operation range is wide, and the efficiency is more than 90% in the range of 25%~120%. The efficiency of permanent magnet motor is higher than the first-level energy efficiency requirement of energy efficiency standard gb30253-2013, efficiency equivalent to IE5.

#### 高功率密度 High power density

我司的普机有降一个机座号,与降两个机座号等非标定制款。电机具有体积小、输出功率大效率高等诸多优点。

Our general machine has a lower number, and lower two number, and other non-standard system. Motor has many advantages such as small volume, high output power and high efficiency.

#### 低温升 Low temperature rise

电机实际余量足,保证电机在满负荷状态下低温升可靠运行;电机采用同轴风扇或独立风机冷却。

The actual margin of the motor is sufficient to ensure the reliable operation of the motor at full load with low temperature rise; The motor is cooled by coaxial fan or independent fan.

#### 通用性 Generality

电机采用标准异步全封闭结构,可满足多种恶劣工况下稳定运行。系列电动机具有超广的适用范围,具备与压缩机完美的匹配性,助推空压机整机效率远超国标1级能效。具备与电梯、风机、水泵、皮带机、机床、纺织机械、电动汽车等器械的高度匹配性,能广泛用于石油、化工、电力、交通、纺织、工矿等行业。

The motor adopts the standard asynchronous completely closed structure, which can meet the stable operation under various bad working conditions. Series motors have a wide range of application, with the perfect matching with the compressor, boost air compressor overall efficiency far more than the national standard level 1 energy efficiency. With elevator, fan, water pump, belt machine, machine tools, textile machinery, electric vehicles and other instruments of high compatibility, can be widely used in petroleum, chemical, electric power, transportation, textile, industrial and mining industries.

JPM永磁电机 (带独立风机系列) 安装及外形尺寸图 JPM Series Motor Mounting and Overall Dimensions

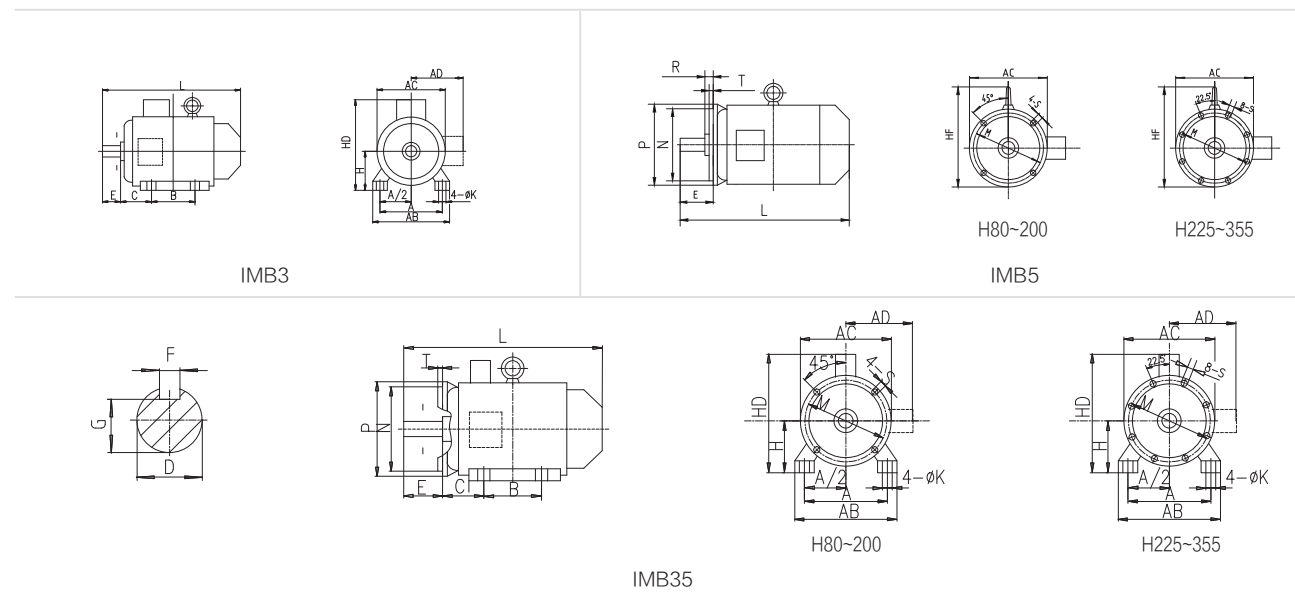

机座号 Frame Size	转速 rpm	安装尺寸 Mounting Dimensions (mm)													外形尺寸 Overall Dimensions (mm)								
		A	B	C	D	E	F	G	H	K	M	N	P	R	S	T	AB	AC	AD	HD	HF	L	
80M	750 1000 1500 3000	125	100	50	19(24)	40	6	15.5	80	10	165	130	200	0	12	3.5	165	175	145	220	245	310	
90S		140	100	56	24	50	8	20	90	10	165	130	200	0	12	3.5	180	205	170	265	270	360	
90L		140	125	56	24	50	8	24	90	10	165	130	200	0	12	3.5	180	205	170	265	270	390	
100L		160	140	63	28	60	8	24	100	12	215	180	250	0	14.5	4	205	215	180	270	305	440	
112M		190	140	70	28	60	8	24	112	12	215	180	250	0	14.5	4	230	255	200	310	275	470	
132S		216	140	89	38(42)	80	10	33	132	12	265	230	300	0	14.5	4	270	310	230	365	335	515	
132M		216	178	89	38(42)	80	10	33	132	12	265	230	300	0	14.5	4	270	310	230	365	335	550	
160M		254	210	108	42(48)	110	12	37	160	14.5	300	250	350	0	18.5	5	320	340	260	425	390	670	
160L		254	254	108	42(48)	110	12	37	160	14.5	300	250	350	0	18.5	5	320	340	260	425	390	700	
180M		279	241	121	48(55)	110	14	42.5	180	14.5	300	250	350	0	18.5	5	355	390	285	460	435	730	
180L		279	279	121	48(55)	110	14	42.5	180	14.5	300	250	350	0	18.5	5	355	390	285	460	435	780	
200L		318	305	133	55(60)	110	16	49	200	18.5	350	300	400	0	18.5	5	395	445	320	520	495	790	
225S		3000	356	286	149	55(60, 65)	110	16	49	225	18.5	400	350	450	0	18.5	5	435	495	350	575	550	790
		750/1000/1500				60(65)	140	18	53	225													830
225M		3000	356	311	149	55(60, 65)	110	16	49	225	18.5	400	350	450	0	18.5	5	435	495	350	575	550	825
		750/1000/1500				60(65)	140	18	53	225													855
250M	3000	406	349	168	60(65, 75)	140	18	53	250	24	500	450	550	0	18.5	5	490	550	390	635	615	920	
	750/1000/1500				65(75)	140	18	58	250														
280S	3000	457	368	190	65(75, 80)	140	18	58	280	24	500	450	550	0	18.5	5	550	630	435	705	675	980	
	750/1000/1500				75(80)	140	20	67.5	280														
280M	3000	457	419	190	65(75, 80)	140	18	58	280	24	500	450	550	0	18.5	5	550	630	435	705	675	1030	
	750/1000/1500				75(80)	140	20	67.5	280														
315S	3000	508	406	216	65(75, 80)	140	18	58	315	28	600	550	660	0	24	6	635	645	530	845	-	1210	
	750/1000/1500				80(95)	170	22	71	315													1240	
315M	3000	508	457	216	65(75, 80)	140	18	58	315	28	600	550	660	0	24	6	635	645	530	845	-	1320	
	750/1000/1500				80(95)	170	22	71	315													1350	
315L	3000	508	508	216	65(75, 80)	140	18	58	315	28	600	550	660	0	24	6	635	645	530	845	-	1320	
	750/1000/1500				80(95)	170	22	71	315													1350	
355M	3000	610	560	254	75(80)	140	20	67.5	355	28	740	680	800	0	24	6	730	710	665	1010	-	1510	
	750/1000/1500				95(110)	170	25	86	355													1550	
355L	3000	610	630	254	75(80)	140	20	67.5	355	28	740	680	800	0	24	6	730	710	665	1010	-	1510	
	750/1000/1500				95(110)	170	25	86	355													1550	
3551	3000	630	800	224	80	170	22	71	355	35	840	780	900	0	24	6	760	770	760	1130	-	1870	
3552	750/1000/1500				110	210	28	100	355													1920	
400	750/1000/1500/3000	686	630/710	280	110	210	28	100	400	35	940	880	1000	0	28	6	806	856	700	1100	-	1925	

注: 若有特殊要求, 可按用户需求提供。 Please contact us with your requirement.

技术数据 Technical Data

类型 Type	电机型号 Type	级数 Pole	额定 功率 Output (kW)	额定 电压 Voltage (V)	频率 (Hz)	额定 电流 Current (A)	接法 Start type	额定 扭矩 (Nm)	额定转速 Rated Speed (r/min)	效率 Efficiency (%)	防护 等级 IP	冷却方式 Cooling mode
3000r/min永磁变频调速电机目录效率标准按照永磁1级能效 3000r/min permanent magnet frequency conversion speed control motor list motor efficiency comply with level 1 of standard efficiency of JPM motor												
标准机座号	JPM80M30-0.75	6	0.75	380	150	1.35	Y	2.39	3000	88.60%	IP55	IC411自冷风扇
标准机座号	JPM80M30-1.1	6	1.1	380	150	1.96	Y	3.50	3000	89.80%	IP55	IC411自冷风扇
标准机座号	JPM90S30-1.5	6	1.5	380	150	2.64	Y	4.78	3000	90.90%	IP55	IC411自冷风扇
标准机座号	JPM90L30-2.2	6	2.2	380	150	3.83	Y	7.00	3000	91.80%	IP55	IC411自冷风扇
标准机座号	JPM100L30-3	6	3	380	150	5.18	Y	9.55	3000	92.60%	IP55	IC411自冷风扇
标准机座号	JPM112M30-4	6	4	380	150	6.86	Y	12.73	3000	93.30%	IP55	IC411自冷风扇
标准机座号	JPM132S30-5.5	6	5.5	380	150	9.50	Y	17.5	3000	94.50%	IP55	IC411自冷风扇
标准机座号	JPM132S30-7.5	6	7.5	380	150	12.92	Y	23.88	3000	94.50%	IP55	IC411自冷风扇
标准机座号	JPM160M30-11	6	11	380	150	18.68	Y	35	3000	95.00%	IP55	IC411自冷风扇
标准机座号	JPM160M30-15	6	15	380	150	25.14	Y	47.8	3000	95.30%	IP55	IC411自冷风扇
标准机座号	JPM160L30-18.5	6	18.5	380	150	31.00	Y	58.9	3000	95.60%	IP55	IC411自冷风扇
标准机座号	JPM180M30-22	8	22	380	200	37.00	Y	70	3000	95.90%	IP55	IC411自冷风扇
标准机座号	JPM200L30-30	8	30	380	200	50.10	Y	95.55	3000	96.10%	IP55	IC411自冷风扇
标准机座号	JPM200L30-37	8	37	380	200	64.00	Y	118	3000	96.30%	IP55	IC411自冷风扇
标准机座号	JPM225M30-45	8	45	380	200	77.90	Y	143.3	3000	96.40%	IP55	IC411自冷风扇
标准机座号	JPM250M30-55	8	55	380	200	94.00	Y	175.2	3000	96.50%	IP55	IC411自冷风扇
标准机座号	JPM280S30-75	8	75	380	200	128.00	Y	238	3000	96.60%	IP55	IC411自冷风扇
标准机座号	JPM280M30-90	8	90	380	200	154.00	Y	286.5	3000	96.70%	IP55	IC411自冷风扇
标准机座号	JPM315S30-110	8	110	380	200	187.50	Y	350	3000	96.80%	IP55	IC411自冷风扇
标准机座号	JPM315M30-132	8	132	380	200	225.00	Y	420	3000	96.90%	IP55	IC411自冷风扇
标准机座号	JPM315L30-160	8	160	380	200	260.00	Y	509	3000	97.00%	IP55	IC411自冷风扇
标准机座号	JPM315L30-185	8	185	380	200	319	Y	588	3000	97.10%	IP55	IC411自冷风扇
标准机座号	JPM315L30-200	8	200	380	200	350.00	Y	636	3000	97.20%	IP55	IC411自冷风扇
标准机座号	JPM355M30-220	8	220	380	200	420.00	Y	700	3000	97.20%	IP55	IC411自冷风扇
标准机座号	JPM355M30-250	8	250	380	200	437.50	Y	795	3000	97.20%	IP55	IC411自冷风扇
标准机座号	JPM355L30-280	8	280	380	200	490.00	Y	891	3000	97.20%	IP55	IC411自冷风扇
标准机座号	JPM355L30-315	8	315	380	200	551.00	Y	1002	3000	97.20%	IP55	IC411自冷风扇
标准机座号	JPM400M30-355	8	355	380	200	620.97	Y	1130.08	3000	97.20%	IP55	IC411自冷风扇
标准机座号	JPM400M30-400	8	400	380	200	699.68	Y	1273.33	3000	97.20%	IP55	IC411自冷风扇
标准机座号	JPM400M30-450	8	450	380	200	787.14	Y	1432.50	3000	97.20%	IP55	IC411自冷风扇
标准机座号	JPM400L30-500	8	500	380	200	874.60	Y	1591.67	3000	97.20%	IP55	IC411自冷风扇
标准机座号	JPM400L30-560	8	560	380	200	979.56	Y	1782.67	3000	97.20%	IP55	IC411自冷风扇
1500r/min永磁变频调速电机目录效率标准按照永磁1级能效 1500r/min permanent magnet frequency conversion speed control motor list motor efficiency comply with level 1 of standard efficiency of JPM motor												
标准机座号	JPM80M15-0.55	6	0.55	380	75	1.03	Y	3.50	1500	85.60%	IP55	IC411自冷风扇
标准机座号	JPM80M15-0.75	6	0.75	380	75	1.4	Y	4.78	1500	85.60%	IP55	IC411自冷风扇
标准机座号	JPM90S15-1.1	6	1.1	380	75	2.01	Y	7.00	1500	87.40%	IP55	IC411自冷风扇
标准机座号	JPM90L15-1.5	6	1.5	380	75	2.72	Y	9.55	1500	88.10%	IP55	IC411自冷风扇
标准机座号	JPM100L15-2.2	6	2.2	380	75	3.92	Y	14.01	1500	89.70%	IP55	IC411自冷风扇
标准机座号	JPM100L15-3	6	3	380	75	5.31	Y	19.10	1500	90.30%	IP55	IC411自冷风扇
标准机座号	JPM112M15-4	6	4	380	75	7.04	Y	25.47	1500	90.90%	IP55	IC411自冷风扇
标准机座号	JPM132S15-5.5	6	5.5	380	75	9.50	Y	34.98	1500	92.10%	IP55	IC411自冷风扇
标准机座号	JPM132M15-7.5	6	7.5	380	75	13	Y	47.8	1500	92.60%	IP55	IC411自冷风扇
标准机座号	JPM160M15-11	6	11	380	75	18.7	Y	70	1500	93.60%	IP55	IC411自冷风扇

技术数据 Technical Data

类型 Type	电机型号 Type	级数 Pole	额定 功率 Output (kW)	额定 电压 Voltage (V)	频率 (Hz)	额定 电流 Current (A)	接法 Start type	额定 扭矩 (Nm)	额定转速 Rated Speed (r/min)	效率 Efficiency (%)	防护 等级 IP	冷却方式 Cooling mode
1500r/min永磁变频调速电机目录效率标准按照永磁1级能效 1500r/min permanent magnet frequency conversion speed control motor list motor efficiency comply with level 1 of standard efficiency of JPM motor												
标准机座号	JPM160L15-15	6	15	380	75	25.2	Y	95.5	1500	94.00%	IP55	IC411自冷风扇
标准机座号	JPM180M15-18.5	8	18.5	380	100	31	Y	117.8	1500	94.30%	IP55	IC411自冷风扇
标准机座号	JPM180L15-22	8	22	380	100	37.00	Y	140.1	1500	94.70%	IP55	IC411自冷风扇
标准机座号	JPM200L15-30	8	30	380	100	50.1	Y	191.1	1500	95.00%	IP55	IC411自冷风扇
标准机座号	JPM225S15-37	8	37	380	100	64	Y	235.7	1500	95.30%	IP55	IC411自冷风扇
标准机座号	JPM225M15-45	8	45	380	100	77.9	Y	286.5	1500	95.60%	IP55	IC411自冷风扇
标准机座号	JPM250M15-55	8	55	380	100	91.8	Y	350	1500	95.80%	IP55	IC411自冷风扇
标准机座号	JPM280S15-75	8	75	380	100	128	Y	478	1500	96.00%	IP55	IC411自冷风扇
标准机座号	JPM280M15-90	8	90	380	100	154	Y	573	1500	96.20%	IP55	IC411自冷风扇
标准机座号	JPM315S15-110	8	110	380	100	178	Y	700	1500	97.00%	IP55	IC411自冷风扇
标准机座号	JPM315M15-132	8	132	380	100	222	Y	840	1500	97.10%	IP55	IC411自冷风扇
标准机座号	JPM315L15-160	8	160	380	100	271	Y	1020	1500	97.20%	IP55	IC411自冷风扇
标准机座号	JPM315L15-185	8	185	380	100	319	Y	1177	1500	97.30%	IP55	IC411自冷风扇
标准机座号	JPM315L15-200	8	200	380	100	350	Y	1273.8	1500	97.40%	IP55	IC411自冷风扇
标准机座号	JPM355M15-250	8	250	380	100	437.5	Y	1592	1500	97.40%	IP55	IC411自冷风扇
标准机座号	JPM355L15-280	8	280	380	100	490	Y	1782	1500	97.40%	IP55	IC411自冷风扇
标准机座号	JPM355L15-315	8	315	380	100	552	Y	2005	1500	97.40%	IP55	IC411自冷风扇
标准机座号	JPM400L15-355	8	355	380	100	623	Y	2260	1500	97.40%	IP55	IC411自冷风扇
标准机座号	JPM400M15-375	8	375	380	100	658	Y	2387	1500	97.40%	IP55	IC411自冷风扇
标准机座号	JPM400M15-400	8	400	380	100	701	Y	2546	1500	97.40%	IP55	IC411自冷风扇
标准机座号	JPM400M15-450	8	450	380	100	788.63	Y	2865.00	1500	97.40%	IP55	IC411自冷风扇
标准机座号	JPM400L15-500	8	500	380	100	876.25	Y	3183.33	1500	97.40%	IP55	IC411自冷风扇
标准机座号	JPM400L15-560	8	560	380	100	981.40	Y	3565.33	1500	97.40%	IP55	IC411自冷风扇
标准机座号	JPM400L15-630	8	630	380	100	1104.08	Y	4011.00	1500	97.40%	IP55	IC411自冷风扇
1000r/min永磁变频调速电机目录效率标准按照永磁1级能效 1000r/min permanent magnet frequency conversion speed control motor list motor efficiency comply with level 1 of standard efficiency of JPM motor												
标准机座号	JPM80M10-0.55	6	0.55	380	50	1.02	Y	5.25	1000	85.90%	IP55	IC411自冷风扇
标准机座号	JPM90S10-0.75	6	0.75	380	50	1.37	Y	7.16	1000	87.40%	IP55	IC411自冷风扇
标准机座号	JPM90L10-1.1	6	1.1	380	50	1.98	Y	10.51	1000	88.70%	IP55	IC411自冷风扇
标准机座号	JPM100L10-1.5	6	1.5	380	50	2.67	Y	14.33	1000	89.90%	IP55	IC411自冷风扇
标准机座号	JPM112M10-2.2	6	2.2	380	50	3.87	Y	21.01	1000	90.90%	IP55	IC411自冷风扇
标准机座号	JPM132S10-3	6	3	380	50	5.21	Y	28.7	1000	91.80%	IP55	IC411自冷风扇
标准机座号	JPM132M10-4	6	4	380	50	6.95	Y	38.2	1000	92.7%	IP55	IC411自冷风扇
标准机座号	JPM132M10-5.5	6	5.5	380	50	9.55	Y	52.5	1000	93.4%	IP55	IC411自冷风扇
标准机座号	JPM160M10-7.5	6	7.5	380	50	13.02	Y	71.6	1000	94%	IP55	IC411自冷风扇
标准机座号	JPM160L10-11	6	11	380	50	19.10	Y	105.1	1000	94.5%	IP55	IC411自冷风扇
标准机座号	JPM180L10-15	8	15	380	66.7	26.05	Y	143.3	1000	94.9%	IP55	IC411自冷风扇
标准机座号	JPM200L10-18.5	8	18.5	380	66.7	32.13	Y	176.7	1000	95.30%	IP55	IC411自冷风扇
标准机座号	JPM200L10-22	8	22	380	66.7	38.20	Y	210.1	1000	95.60%	IP55	IC411自冷风扇
标准机座号	JPM225M10-30	8	30	380	66.7	52.10	Y	286.5	1000	95.80%	IP55	IC411自冷风扇
标准机座号	JPM250M10-37	8	37	380	66.7	64.25	Y	353.4	1000	96.00%	IP55	IC411自冷风扇
标准机座号	JPM250M10-45	8	45	380	66.7	78.14	Y	429.8	1000	96.20%	IP55	IC411自冷风扇
标准机座号	JPM280S10-45	8	45	380	66.7	78.14	Y	429.8	1000	96.20%	IP55	IC411自冷风扇
标准机座号	JPM280M10-55	8	55	380	66.7	95.51	Y	525.3	1000	96.30%	IP55	IC411自冷风扇

技术数据 Technical Data

类型 Type	电机型号 Type	级数 Pole	额定 功率 Output (kW)	额定 电压 Voltage (V)	频率 (Hz)	额定 电流 Current (A)	接法 Start type	额定 扭矩 (Nm)	额定转速 Rated Speed (r/min)	效率 Efficiency (%)	防护 等级 IP	冷却方式 Cooling mode
1000r/min永磁变频调速电机目录效率标准按照永磁1级能效 1000r/min permanent magnet frequency conversion speed control motor list motor efficiency comply with level 1 of standard efficiency of JPM motor												
标准机座号	JPM315S10-75	8	75	380	66.7	130.24	Y	716.3	1000	96.40%	IP55	IC411自冷风扇
标准机座号	JPM315M10-90	8	90	380	66.7	156.29	Y	859.5	1000	96.50%	IP55	IC411自冷风扇
标准机座号	JPM315L10-110	8	110	380	66.7	191.02	Y	1050.5	1000	96.60%	IP55	IC411自冷风扇
标准机座号	JPM315L10-132	8	132	380	66.7	229.22	Y	1260.6	1000	96.80%	IP55	IC411自冷风扇
标准机座号	JPM355M10-160	8	160	380	66.7	277.80	Y	1528.0	1000	96.90%	IP55	IC411自冷风扇
标准机座号	JPM355M10-185	8	185	380	66.7	322.00	Y	1766.0	1000	97.00%	IP55	IC411自冷风扇
标准机座号	JPM355M10-200	8	200	380	66.7	347.00	Y	1910.0	1000	97.00%	IP55	IC411自冷风扇
标准机座号	JPM355M10-220	8	220	380	66.7	381.70	Y	2101.00	1000	97.00%	IP55	IC411自冷风扇
标准机座号	JPM355L10-250	8	250	380	66.7	434.00	Y	2387.0	1000	97.00%	IP55	IC411自冷风扇
标准机座号	JPM355L10-280	8	280	380	66.7	486.00	Y	2674.0	1000	97.00%	IP55	IC411自冷风扇
标准机座号	JPM400M10-315	8	315	380	66.7	546.00	Y	3008.0	1000	97.00%	IP55	IC411自冷风扇
标准机座号	JPM400M10-355	8	355	380	66.7	616.00	Y	3390.0	1000	97.00%	IP55	IC411自冷风扇
标准机座号	JPM400M10-400	8	400	380	66.7	694.08	Y	3820.00	1000	97.00%	IP55	IC411自冷风扇
标准机座号	JPM400M10-450	8	450	380	66.7	780.85	Y	4297.50	1000	97.00%	IP55	IC411自冷风扇
750r/min永磁变频调速电机目录效率标准按照永磁1级能效 750r/min permanent magnet frequency conversion speed control motor list motor efficiency comply with level 1 of standard efficiency of JPM motor												
标准机座号	JPM90L7.5-0.55	6	0.55	380	37.5	1.11	Y	7.0	750	83.85%	IP55	IC411自冷风扇
标准机座号	JPM100L7.5-0.75	6	0.75	380	37.5	1.43	Y	9.6	750	84.85%	IP55	IC411自冷风扇
标准机座号	JPM100L7.5-1.1	6	1.1	380	37.5	2.06	Y	14.0	750	86.00%	IP55	IC411自冷风扇
标准机座号	JPM112M7.5-1.5	6	1.5	380	37.5	2.06	Y	19.1	750	87.20%	IP55	IC411自冷风扇
标准机座号	JPM132S7.5-2.2	6	2.2	380	37.5	3.82	Y	28.0	750	88.10%	IP55	IC411自冷风扇
标准机座号	JPM132M7.5-3	6	3	380	37.5	5.21	Y	38.2	750	88.95%	IP55	IC411自冷风扇
标准机座号	JPM160M7.5-4	6	4	380	37.5	6.95	Y	50.9	750	90.15%	IP55	IC411自冷风扇
标准机座号	JPM160M7.5-5.5	6	5.5	380	37.5	9.55	Y	70.0	750	90.90%	IP55	IC411自冷风扇
标准机座号	JPM160L7.5-7.5	6	7.5	380	37.5	13.02	Y	95.5	750	91.45%	IP55	IC411自冷风扇
标准机座号	JPM180L7.5-11	8	11	380	50	19.10	Y	140.1	750	92.70%	IP55	IC411自冷风扇
标准机座号	JPM200L7.5-15	8	15	380	50	26.05	Y	191.0	750	93.25%	IP55	IC411自冷风扇
标准机座号	JPM225S7.5-18.5	8	18.5	380	50	32.13	Y	235.6	750	94.00%	IP55	IC411自冷风扇
标准机座号	JPM225M7.5-22	8	22	380	50	38.20	Y	280.1	750	94.45%	IP55	IC411自冷风扇
标准机座号	JPM250M7.5-30	8	30	380	50	52.10	Y	382.0	750	94.70%	IP55	IC411自冷风扇
标准机座号	JPM280S7.5-37	8	37	380	50	64.25	Y	471.1	750	94.95%	IP55	IC411自冷风扇
标准机座号	JPM280M7.5-45	8	45	380	50	78.14	Y	573.0	750	95.20%	IP55	IC411自冷风扇
标准机座号	JPM315S7.5-55	8	55	380	50	95.51	Y	700.3	750	95.40%	IP55	IC411自冷风扇
标准机座号	JPM315M7.5-75	8	75	380	50	130.24	Y	955.0	750	95.55%	IP55	IC411自冷风扇
标准机座号	JPM315L7.5-90	8	90	380	50	156.29	Y	1146.0	750	95.60%	IP55	IC411自冷风扇
标准机座号	JPM315L7.5-110	8	110	380	50	191.02	Y	1400.0	750	96.90%	IP55	IC411自冷风扇
标准机座号	JPM355M7.5-132	8	132	380	50	229.00	Y	1680.0	750	97.10%	IP55	IC411自冷风扇
标准机座号	JPM355M7.5-160	8	160	380	50	278.00	Y	2037.0	750	97.20%	IP55	IC411自冷风扇
标准机座号	JPM355L7.5-185	8	185	380	50	322.00	Y	2355.7	750	97.50%	IP55	IC411自冷风扇
标准机座号	JPM355L7.5-200	8	200	380	50	347.00	Y	2546.0	750	97.50%	IP55	IC411自冷风扇
标准机座号	JPM400M7.5-250	8	250	380	50	434.00	Y	3183.0	750	97.50%	IP55	IC411自冷风扇
标准机座号	JPM400M7.5-280	8	280	380	50	486.08	Y	3565.33	750	97.50%	IP55	IC411自冷风扇
标准机座号	JPM400M7.5-315	8	315	380	50	547.00	Y	4011.0	750	97.50%	IP55	IC411自冷风扇
标准机座号	JPM400M7.5-375	8	375	380	50	651.00	Y	4775.0	750	97.50%	IP55	IC411自冷风扇
标准机座号	JPM400M7.5-400	8	400	380	50	694.00	Y	5093.0	750	97.50%	IP55	IC411自冷风扇

注: 若有特殊要求, 可按用户需求提供。 Please contact us with your requirement.



技术数据 Technical Data

类型 Type	电机型号 Type	级数 Pole	额定 功率 Output (kW)	额定 电压 Voltage (V)	频率 (Hz)	额定 电流 Current (A)	接法 Start type	额定 扭矩 (Nm)	额定转速 Rated Speed (r/min)	效率 Efficiency (%)	防护 等级 IP	冷却方式 Cooling mode
3000r/min永磁变频调速电机目录效率标准按照永磁1级能效 3000r/min permanent magnet frequency conversion speed control motor list motor efficiency comply with level 1 of standard efficiency of JPM motor												
降一个机座号	JPM80M30-1.5	6	1.5	380	150	2.64	Y	4.78	3000	90.90%	IP55	IC411自冷风扇
降一个机座号	JPM90L30-3	6	3	380	150	5.18	Y	9.55	3000	92.60%	IP55	IC411自冷风扇
降一个机座号	JPM100L30-4	6	4	380	150	6.86	Y	12.73	3000	93.30%	IP55	IC411自冷风扇
降一个机座号	JPM112M30-5.5	6	5.5	380	150	9.50	Y	17.5	3000	94.50%	IP55	IC411自冷风扇
降一个机座号	JPM112M30-7.5	6	7.5	380	150	12.92	Y	23.88	3000	94.50%	IP55	IC411自冷风扇
降一个机座号	JPM132M30-11	6	11	380	150	18.68	Y	35	3000	95.00%	IP55	IC411自冷风扇
降一个机座号	JPM132M30-15	6	15	380	150	25.14	Y	47.8	3000	95.30%	IP55	IC411自冷风扇
降一个机座号	JPM132M30-18.5	6	18.5	380	150	31.00	Y	58.9	3000	95.60%	IP55	IC411自冷风扇
降一个机座号	JPM160M30-22	6	22	380	150	37.00	Y	70	3000	95.90%	IP55	IC411自冷风扇
降一个机座号	JPM180M30-30	8	30	380	200	50.10	Y	95.55	3000	96.10%	IP55	IC411自冷风扇
降一个机座号	JPM180M30-37	8	37	380	200	64.00	Y	118	3000	96.30%	IP55	IC411自冷风扇
降一个机座号	JPM200L30-45	8	45	380	200	77.90	Y	143.3	3000	96.40%	IP55	IC411自冷风扇
降一个机座号	JPM225M30-55	8	55	380	200	94.00	Y	175.2	3000	96.50%	IP55	IC411自冷风扇
降一个机座号	JPM250M30-75	8	75	380	200	128.00	Y	238	3000	96.60%	IP55	IC411自冷风扇
降一个机座号	JPM250M30-90	8	90	380	200	154.00	Y	286.5	3000	96.70%	IP55	IC411自冷风扇
降一个机座号	JPM280S30-110	8	110	380	200	187.50	Y	350	3000	96.80%	IP55	IC411自冷风扇
降一个机座号	JPM280S30-132	8	132	380	200	225.00	Y	420	3000	96.90%	IP55	IC411自冷风扇
降一个机座号	JPM280M30-160	8	160	380	200	260.00	Y	509	3000	97.00%	IP55	IC411自冷风扇
降一个机座号	JPM280M30-185	8	185	380	200	319	Y	588	3000	97.10%	IP55	IC411自冷风扇
降一个机座号	JPM315M30-220	8	220	380	200	420.00	Y	700	3000	97.20%	IP55	IC411自冷风扇
降一个机座号	JPM315M30-250	8	250	380	200	437.50	Y	795	3000	97.20%	IP55	IC411自冷风扇
降一个机座号	JPM315L30-280	8	280	380	200	490.00	Y	891	3000	97.20%	IP55	IC411自冷风扇
降一个机座号	JPM315L30-315	8	315	380	200	551.00	Y	1002	3000	97.20%	IP55	IC411自冷风扇
降一个机座号	JPM355M30-355	8	355	380	200	620.97	Y	1130.08	3000	97.20%	IP55	IC411自冷风扇
降一个机座号	JPM355M30-375	8	375	380	200	656.00	Y	1193	3000	97.20%	IP55	IC411自冷风扇
降一个机座号	JPM355M30-400	8	400	380	200	699.00	Y	1273	3000	97.20%	IP55	IC411自冷风扇
降一个机座号	JPM355M30-450	8	450	380	200	786.00	Y	1432	3000	97.20%	IP55	IC411自冷风扇
降一个机座号	JPM355M30-500	8	500	380	200	875.00	Y	1591	3000	97.20%	IP55	IC411自冷风扇
降一个机座号	JPM355M30-560	8	560	380	200	979.00	Y	1783	3000	97.20%	IP55	IC411自冷风扇
降一个机座号	JPM400M30-630	8	630	380	200	1100.00	Y	2006	3000	97.20%	IP55	IC411自冷风扇
降一个机座号	JPM400M30-710	8	710	380	200	1240.00	Y	2260	3000	97.20%	IP55	IC411自冷风扇
1500r/min永磁变频调速电机目录效率标准按照永磁1级能效 1500r/min permanent magnet frequency conversion speed control motor list motor efficiency comply with level 1 of standard efficiency of JPM motor												
降一个机座号	JPM80M15-1.5	6	1.5	380	75	2.72	Y	9.55	1500	88.10%	IP55	IC411自冷风扇
降一个机座号	JPM90L15-1.1	6	1.1	380	75	2.01	Y	7.00	1500	87.40%	IP55	IC411自冷风扇
降一个机座号	JPM90L15-2.2	6	2.2	380	75	3.92	Y	14.01	1500	89.70%	IP55	IC411自冷风扇
降一个机座号	JPM90L15-3	6	3	380	75	5.31	Y	19.10	1500	90.30%	IP55	IC411自冷风扇
降一个机座号	JPM100L15-4	6	4	380	75	7.04	Y	25.47	1500	90.90%	IP55	IC411自冷风扇
降一个机座号	JPM112M15-5.5	6	5.5	380	75	9.50	Y	34.98	1500	92.10%	IP55	IC411自冷风扇
降一个机座号	JPM112M15-7.5	6	7.5	380	75	13	Y	47.8	1500	92.60%	IP55	IC411自冷风扇
降一个机座号	JPM132M15-11	6	11	380	75	18.7	Y	70	1500	93.60%	IP55	IC411自冷风扇
降一个机座号	JPM132M15-15	6	15	380	75	25.2	Y	95.5	1500	94.00%	IP55	IC411自冷风扇
降一个机座号	JPM160M15-18.5	6	18.5	380	75	31	Y	117.8	1500	94.30%	IP55	IC411自冷风扇
降一个机座号	JPM160L15-22	6	22	380	75	37.00	Y	140.1	1500	94.70%	IP55	IC411自冷风扇

技术数据 Technical Data

类型 Type	电机型号 Type	级数 Pole	额定 功率 Output (kW)	额定 电压 Voltage (V)	频率 (Hz)	额定 电流 Current (A)	接法 Start type	额定 扭矩 (Nm)	额定转速 Rated Speed (r/min)	效率 Efficiency (%)	防护 等级 IP	冷却方式 Cooling mode
1500r/min永磁变频调速电机目录效率标准按照永磁1级能效 1500r/min permanent magnet frequency conversion speed control motor list motor efficiency comply with level 1 of standard efficiency of JPM motor												
降一个机座号	JPM180L15-30	8	30	380	100	50.1	Y	191.1	1500	95.00%	IP55	IC411自冷风扇
降一个机座号	JPM200L15-37	8	37	380	100	64	Y	235.7	1500	95.30%	IP55	IC411自冷风扇
降一个机座号	JPM225M15-55	8	55	380	100	91.8	Y	350	1500	95.80%	IP55	IC411自冷风扇
降一个机座号	JPM250M15-75	8	75	380	100	128	Y	478	1500	96.00%	IP55	IC411自冷风扇
降一个机座号	JPM250M15-90	8	90	380	100	154	Y	573	1500	96.20%	IP55	IC411自冷风扇
降一个机座号	JPM280M15-110	8	110	380	100	178	Y	700	1500	97.00%	IP55	IC411自冷风扇
降一个机座号	JPM280M15-132	8	132	380	100	222	Y	840	1500	97.10%	IP55	IC411自冷风扇
降一个机座号	JPM315M15-250	8	250	380	100	437.5	Y	1592	1500	97.40%	IP55	IC411自冷风扇
降一个机座号	JPM315L15-280	8	280	380	100	490	Y	1782	1500	97.40%	IP55	IC411自冷风扇
降一个机座号	JPM315L15-315	8	315	380	100	552	Y	2005	1500	97.40%	IP55	IC411自冷风扇
降一个机座号	JPM355M15-355	8	355	380	100	623	Y	2260	1500	97.40%	IP55	IC411自冷风扇
降一个机座号	JPM355M15-400	8	400	380	100	701	Y	2546	1500	97.40%	IP55	IC411自冷风扇
降一个机座号	JPM355M15-450	8	450	380	100	788.7	Y	2865	1500	97.40%	IP55	IC411自冷风扇
降一个机座号	JPM355M15-500	8	500	380	100	877	Y	3183	1500	97.40%	IP55	IC411自冷风扇
降一个机座号	JPM355M15-560	8	560	380	100	982	Y	3565	1500	97.40%	IP55	IC411自冷风扇
降一个机座号	JPM400M15-630	8	630	380	100	1104	Y	4011	1500	97.40%	IP55	IC411自冷风扇
降一个机座号	JPM400M15-710	8	710	380	100	1244	Y	4520	1500	97.40%	IP55	IC411自冷风扇
降一个机座号	JPM400M15-800	8	800	380	100	1401	Y	5093	1500	97.40%	IP55	IC411自冷风扇
1000r/min永磁变频调速电机目录效率标准按照永磁1级能效 1000r/min permanent magnet frequency conversion speed control motor list motor efficiency comply with level 1 of standard efficiency of JPM motor												
降一个机座号	JPM80M10-0.75	6	0.75	380	50	1.37	Y	7.16	1000	87.40%	IP55	IC411自冷风扇
降一个机座号	JPM80M10-1.1	6	1.1	380	50	1.98	Y	10.51	1000	88.70%	IP55	IC411自冷风扇
降一个机座号	JPM90L10-1.5	6	1.5	380	50	2.67	Y	14.33	1000	89.90%	IP55	IC411自冷风扇
降一个机座号	JPM100L10-2.2	6	2.2	380	50	3.87	Y	21.01	1000	90.90%	IP55	IC411自冷风扇
降一个机座号	JPM112M10-3	6	3	380	50	5.21	Y	28.7	1000	91.80%	IP55	IC411自冷风扇
降一个机座号	JPM112M10-4	6	4	380	50	6.95	Y	38.2	1000	92.7%	IP55	IC411自冷风扇
降一个机座号	JPM132M10-7.5	6	7.5	380	50	13.02	Y	71.6	1000	94%	IP55	IC411自冷风扇
降一个机座号	JPM160L10-15	6	15	380	50	26.05	Y	143.3	1000	94.9%	IP55	IC411自冷风扇
降一个机座号	JPM180M10-18.5	8	18.5	380	66.7	32.13	Y	176.7	1000	95.30%	IP55	IC411自冷风扇
降一个机座号	JPM180L10-22	8	22	380	66.7	38.20	Y	210.1	1000	95.60%	IP55	IC411自冷风扇
降一个机座号	JPM200L10-30	8	30	380	66.7	52.10	Y	286.5	1000	95.80%	IP55	IC411自冷风扇
降一个机座号	JPM225M10-37	8	37	380	66.7	64.25	Y	353.4	1000	96.00%	IP55	IC411自冷风扇
降一个机座号	JPM225M10-45	8	45	380	66.7	78.14	Y	429.8	1000	96.20%	IP55	IC411自冷风扇
降一个机座号	JPM250M10-55	8	55	380	66.7	95.51	Y	525.3	1000	96.30%	IP55	IC411自冷风扇
降一个机座号	JPM280M10-75	8	75	380	66.7	130.24	Y	716.3	1000	96.40%	IP55	IC411自冷风扇
降一个机座号	JPM280M10-90	8	90	380	66.7	156.29	Y	859.5	1000	96.50%	IP55	IC411自冷风扇
降一个机座号	JPM315M10-160	8	160	380	66.7	277.80	Y	1528.0	1000	96.90%	IP55	IC411自冷风扇
降一个机座号	JPM315M10-185	8	185	380	66.7	322.00	Y	1766.0	1000	97.00%	IP55	IC411自冷风扇
降一个机座号	JPM315M10-200	8	200	380	66.7	347.00	Y	1910.0	1000	97.00%	IP55	IC411自冷风扇
降一个机座号	JPM315L10-220	8	220	380	66.7	381.70	Y	2101.00	1000	97.00%	IP55	IC411自冷风扇
降一个机座号	JPM315L10-250	8	250	380	66.7	434.00	Y	2387.0	1000	97.00%	IP55	IC411自冷风扇
降一个机座号	JPM355M10-315	8	315	380	66.7	546.00	Y	3008.0	1000	97.00%	IP55	IC411自冷风扇
降一个机座号	JPM355M10-355	8	355	380	66.7	616.00	Y	3390.0	1000	97.00%	IP55	IC411自冷风扇
降一个机座号	JPM355M10-400	8	400	380	66.7	694.08	Y	3820.00	1000	97.00%	IP55	IC411自冷风扇

技术数据 Technical Data

类型 Type	电机型号 Type	级数 Pole	额定 功率 Output (kW)	额定 电压 Voltage (V)	频率 (Hz)	额定 电流 Current (A)	接法 Start type	额定 扭矩 (Nm)	额定转速 Rated Speed (r/min)	效率 Efficiency (%)	防护 等级 IP	冷却方式 Cooling mode
1000r/min永磁变频调速电机目录效率标准按照永磁1级能效 1000r/min permanent magnet frequency conversion speed control motor list motor efficiency comply with level 1 of standard efficiency of JPM motor												
降一个机座号	JPM355M10-450	8	450	380	66.7	781.00	Y	4297.0	1000	97.00%	IP55	IC411自冷风扇
降一个机座号	JPM355M10-500	8	500	380	66.7	868.00	Y	4775.0	1000	97.00%	IP55	IC411自冷风扇
降一个机座号	JPM355M10-560	8	560	380	66.7	972.00	Y	5348.0	1000	97.00%	IP55	IC411自冷风扇
降一个机座号	JPM400M10-450	8	450	380	66.7	781.00	Y	4297.0	1000	97.00%	IP55	IC411自冷风扇
降一个机座号	JPM400M10-500	8	500	380	66.7	868.00	Y	4775.0	1000	97.00%	IP55	IC411自冷风扇
降一个机座号	JPM400M10-560	8	560	380	66.7	972.00	Y	5348.0	1000	97.00%	IP55	IC411自冷风扇
降一个机座号	JPM400M10-630	8	630	380	66.7	1093.50	Y	6016.0	1000	97.00%	IP55	IC411自冷风扇
降一个机座号	JPM400M10-710	8	710	380	66.7	1232.36	Y	6780.0	1000	97.00%	IP55	IC411自冷风扇
降一个机座号	JPM400M10-800	8	800	380	66.7	1388.57	Y	7640.0	1000	97.00%	IP55	IC411自冷风扇
750r/min永磁变频调速电机目录效率标准按照永磁1级能效 750r/min permanent magnet frequency conversion speed control motor list motor efficiency comply with level 1 of standard efficiency of JPM motor												
降一个机座号	JPM80M7.5-0.55	6	0.55	380	37.5	1.11	Y	7.0	750	83.85%	IP55	IC411自冷风扇
降一个机座号	JPM90L7.5-0.75	6	0.75	380	37.5	1.43	Y	9.6	750	84.85%	IP55	IC411自冷风扇
降一个机座号	JPM90L7.5-1.1	6	1.1	380	37.5	2.06	Y	14.0	750	86.00%	IP55	IC411自冷风扇
降一个机座号	JPM100L7.5-1.5	6	1.5	380	37.5	2.06	Y	19.1	750	87.20%	IP55	IC411自冷风扇
降一个机座号	JPM112M7.5-2.2	6	2.2	380	37.5	3.82	Y	28.0	750	88.10%	IP55	IC411自冷风扇
降一个机座号	JPM112M7.5-3	6	3	380	37.5	5.21	Y	38.2	750	88.95%	IP55	IC411自冷风扇
降一个机座号	JPM132M7.5-4	6	4	380	37.5	6.95	Y	50.9	750	90.15%	IP55	IC411自冷风扇
降一个机座号	JPM132S7.5-5.5	6	5.5	380	37.5	9.55	Y	70.0	750	90.90%	IP55	IC411自冷风扇
降一个机座号	JPM132S7.5-7.5	6	7.5	380	37.5	13.02	Y	95.5	750	91.45%	IP55	IC411自冷风扇
降一个机座号	JPM160L7.5-11	6	11	380	37.5	19.10	Y	140.1	750	92.70%	IP55	IC411自冷风扇
降一个机座号	JPM180L7.5-15	8	15	380	50	26.05	Y	191.0	750	93.25%	IP55	IC411自冷风扇
降一个机座号	JPM200L7.5-18.5	8	18.5	380	50	32.13	Y	235.6	750	94.00%	IP55	IC411自冷风扇
降一个机座号	JPM200L7.5-22	8	22	380	50	38.20	Y	280.1	750	94.45%	IP55	IC411自冷风扇
降一个机座号	JPM225M7.5-30	8	30	380	50	52.10	Y	382.0	750	94.70%	IP55	IC411自冷风扇
降一个机座号	JPM250M7.5-37	8	37	380	50	64.25	Y	471.1	750	94.95%	IP55	IC411自冷风扇
降一个机座号	JPM250M7.5-45	8	45	380	50	78.14	Y	573.0	750	95.20%	IP55	IC411自冷风扇
降一个机座号	JPM280M7.5-55	8	55	380	50	95.51	Y	700.3	750	95.40%	IP55	IC411自冷风扇
降一个机座号	JPM280M7.5-75	8	75	380	50	130.24	Y	955.0	750	95.55%	IP55	IC411自冷风扇
降一个机座号	JPM280M7.5-90	8	90	380	50	156.29	Y	1146.0	750	95.60%	IP55	IC411自冷风扇
降一个机座号	JPM315M7.5-132	8	132	380	50	229.00	Y	1680.0	750	97.10%	IP55	IC411自冷风扇
降一个机座号	JPM315M7.5-160	8	160	380	50	278.00	Y	2037.0	750	97.20%	IP55	IC411自冷风扇
降一个机座号	JPM355M7.5-250	8	250	380	50	434.00	Y	3183.0	750	97.50%	IP55	IC411自冷风扇
降一个机座号	JPM355M7.5-280	8	280	380	50	486.08	Y	3565.33	750	97.50%	IP55	IC411自冷风扇
降一个机座号	JPM355M7.5-315	8	315	380	50	547.00	Y	4011.0	750	97.50%	IP55	IC411自冷风扇
降一个机座号	JPM355M7.5-375	8	375	380	50	651.00	Y	4775.0	750	97.50%	IP55	IC411自冷风扇
降一个机座号	JPM355M7.5-400	8	400	380	50	694.00	Y	5093.0	750	97.50%	IP55	IC411自冷风扇
降一个机座号	JPM400M7.5-450	8	450	380	50	782.00	Y	5730.0	750	97.50%	IP55	IC411自冷风扇
降一个机座号	JPM400M7.5-500	8	500	380	50	868.00	Y	6366.0	750	97.50%	IP55	IC411自冷风扇
降一个机座号	JPM400M7.5-560	8	560	380	50	972.00	Y	7130.0	750	97.50%	IP55	IC411自冷风扇
降一个机座号	JPM400M7.5-630	8	630	380	50	1094.00	Y	8022.0	750	97.50%	IP55	IC411自冷风扇

注: 若有特殊要求, 可按用户需求提供。 Please contact us with your requirement.

技术数据 Technical Data

类型 Type	电机型号 Type	级数 Pole	额定 功率 Output (kW)	额定 电压 Voltage (V)	频率 (Hz)	额定 电流 Current (A)	接法 Start type	额定 扭矩 (Nm)	额定转速 Rated Speed (r/min)	效率 Efficiency (%)	防护 等级 IP	冷却方式 Cooling mode
3000r/min永磁变频调速电机目录效率标准按照永磁1级能效 3000r/min permanent magnet frequency conversion speed control motor list motor efficiency comply with level 1 of standard efficiency of JPM motor												
降两个机座号	JPM80M30-3	6	3	380	150	5.18	Y	9.55	3000	92.60%	IP55	IC411自冷风扇
降两个机座号	JPM90L30-4	6	4	380	150	6.86	Y	12.73	3000	93.30%	IP55	IC411自冷风扇
降两个机座号	JPM100L30-5.5	6	5.5	380	150	9.50	Y	17.5	3000	94.50%	IP55	IC411自冷风扇
降两个机座号	JPM100L30-7.5	6	7.5	380	150	12.92	Y	23.88	3000	94.50%	IP55	IC411自冷风扇
降两个机座号	JPM112M30-11	6	11	380	150	18.68	Y	35	3000	95.00%	IP55	IC411自冷风扇
降两个机座号	JPM112M30-15	6	15	380	150	25.14	Y	47.8	3000	95.30%	IP55	IC411自冷风扇
降两个机座号	JPM112M30-18.5	6	18.5	380	150	31.00	Y	58.9	3000	95.60%	IP55	IC411自冷风扇
降两个机座号	JPM132M30-22	8	22	380	200	37.00	Y	70	3000	95.90%	IP55	IC411自冷风扇
降两个机座号	JPM160M30-30	8	30	380	200	50.10	Y	95.55	3000	96.10%	IP55	IC411自冷风扇
降两个机座号	JPM160M30-37	8	37	380	200	64.00	Y	118	3000	96.30%	IP55	IC411自冷风扇
降两个机座号	JPM180M30-45	8	45	380	200	77.90	Y	143.3	3000	96.40%	IP55	IC411自冷风扇
降两个机座号	JPM200L30-55	8	55	380	200	94.00	Y	175.2	3000	96.50%	IP55	IC411自冷风扇
降两个机座号	JPM225M30-75	8	75	380	200	128.00	Y	238	3000	96.60%	IP55	IC411自冷风扇
降两个机座号	JPM225M30-90	8	90	380	200	154.00	Y	286.5	3000	96.70%	IP55	IC411自冷风扇
降两个机座号	JPM250M30-110	8	110	380	200	187.50	Y	350	3000	96.80%	IP55	IC411自冷风扇
降两个机座号	JPM250M30-132	8	132	380	200	225.00	Y	420	3000	96.90%	IP55	IC411自冷风扇
降两个机座号	JPM250M30-160	8	160	380	200	260.00	Y	509	3000	97.00%	IP55	IC411自冷风扇
降两个机座号	JPM250M30-185	8	185	380	200	319	Y	588	3000	97.10%	IP55	IC411自冷风扇
降两个机座号	JPM250M30-200	8	200	380	200	350.00	Y	636	3000	97.20%	IP55	IC411自冷风扇
降两个机座号	JPM280M30-220	8	220	380	200	420.00	Y	700	3000	97.20%	IP55	IC411自冷风扇
降两个机座号	JPM280M30-250	8	250	380	200	437.50	Y	795	3000	97.20%	IP55	IC411自冷风扇
降两个机座号	JPM280M30-280	8	280	380	200	490.00	Y	891	3000	97.20%	IP55	IC411自冷风扇
降两个机座号	JPM280M30-315	8	315	380	200	551.00	Y	1002	3000	97.20%	IP55	IC411自冷风扇
降两个机座号	JPM315M30-355	8	355	380	200	620.97	Y	1130.08	3000	97.20%	IP55	IC411自冷风扇
降两个机座号	JPM315M30-400	8	400	380	200	699.68	Y	1273.33	3000	97.20%	IP55	IC411自冷风扇
降两个机座号	JPM315M30-450	8	450	380	200	787.14	Y	1432.50	3000	97.20%	IP55	IC411自冷风扇
降两个机座号	JPM315L30-500	8	500	380	200	874.60	Y	1591.67	3000	97.20%	IP55	IC411自冷风扇
降两个机座号	JPM315L30-560	8	560	380	200	979.56	Y	1782.67	3000	97.20%	IP55	IC411自冷风扇
降两个机座号	JPM355M30-630	8	630	380	200	1100.00	Y	2006.0	3000	97.20%	IP55	IC411自冷风扇
降两个机座号	JPM355M30-710	8	710	380	200	1240.00	Y	2260.0	3000	97.20%	IP55	IC411自冷风扇
1500r/min永磁变频调速电机目录效率标准按照永磁1级能效 1500r/min permanent magnet frequency conversion speed control motor list motor efficiency comply with level 1 of standard efficiency of JPM motor												
降两个机座号	JPM80M15-2.2	6	2.2	380	75	3.92	Y	14.01	1500	89.70%	IP55	IC411自冷风扇
降两个机座号	JPM80M15-3	6	3	380	75	5.31	Y	19.10	1500	90.30%	IP55	IC411自冷风扇
降两个机座号	JPM90L15-4	6	4	380	75	7.04	Y	25.47	1500	90.90%	IP55	IC411自冷风扇
降两个机座号	JPM100L15-5.5	6	5.5	380	75	9.50	Y	34.98	1500	92.10%	IP55	IC411自冷风扇
降两个机座号	JPM100L15-7.5	6	7.5	380	75	13	Y	47.8	1500	92.60%	IP55	IC411自冷风扇
降两个机座号	JPM112M15-11	6	11	380	75	18.7	Y	70	1500	93.60%	IP55	IC411自冷风扇
降两个机座号	JPM112M15-15	6	15	380	75	25.2	Y	95.5	1500	94.00%	IP55	IC411自冷风扇
降两个机座号	JPM132M15-18.5	6	18.5	380	75	31	Y	117.8	1500	94.30%	IP55	IC411自冷风扇
降两个机座号	JPM132M15-22	6	22	380	75	37.00	Y	140.1	1500	94.70%	IP55	IC411自冷风扇
降两个机座号	JPM160L15-30	6	30	380	75	50.1	Y	191.1	1500	95.00%	IP55	IC411自冷风扇
降两个机座号	JPM180L15-37	8	37	380	100	64	Y	235.7	1500	95.30%	IP55	IC411自冷风扇
降两个机座号	JPM180L15-45	8	45	380	100	77.9	Y	286.5	1500	95.60%	IP55	IC411自冷风扇

技术数据 Technical Data

类型 Type	电机型号 Type	级数 Pole	额定 功率 Output (kW)	额定 电压 Voltage (V)	频率 (Hz)	额定 电流 Current (A)	接法 Start type	额定 扭矩 (Nm)	额定转速 Rated Speed (r/min)	效率 Efficiency (%)	防护 等级 IP	冷却方式 Cooling mode
1500r/min永磁变频调速电机目录效率标准按照永磁1级能效 1500r/min permanent magnet frequency conversion speed control motor list motor efficiency comply with level 1 of standard efficiency of JPM motor												
降两个机座号	JPM200L15-55	8	55	380	100	91.8	Y	350	1500	95.80%	IP55	IC411自冷风扇
降两个机座号	JPM225M15-75	8	75	380	100	128	Y	478	1500	96.00%	IP55	IC411自冷风扇
降两个机座号	JPM225M15-90	8	90	380	100	154	Y	573	1500	96.20%	IP55	IC411自冷风扇
降两个机座号	JPM250M15-110	8	110	380	100	178	Y	700	1500	97.00%	IP55	IC411自冷风扇
降两个机座号	JPM250M15-132	8	132	380	100	222	Y	840	1500	97.10%	IP55	IC411自冷风扇
降两个机座号	JPM250M15-160	8	160	380	100	271	Y	1020	1500	97.20%	IP55	IC411自冷风扇
降两个机座号	JPM250M15-185	8	185	380	100	319	Y	1177	1500	97.30%	IP55	IC411自冷风扇
降两个机座号	JPM250M15-200	8	200	380	100	350	Y	1273.8	1500	97.40%	IP55	IC411自冷风扇
降两个机座号	JPM280M15-250	8	250	380	100	437.5	Y	1592	1500	97.40%	IP55	IC411自冷风扇
降两个机座号	JPM280M15-280	8	280	380	100	490	Y	1782	1500	97.40%	IP55	IC411自冷风扇
降两个机座号	JPM280M15-315	8	315	380	100	552	Y	2005	1500	97.40%	IP55	IC411自冷风扇
降两个机座号	JPM315M15-355	8	355	380	100	623	Y	2260	1500	97.40%	IP55	IC411自冷风扇
降两个机座号	JPM315M15-375	8	375	380	100	658	Y	2387	1500	97.40%	IP55	IC411自冷风扇
降两个机座号	JPM315M15-400	8	400	380	100	701	Y	2546	1500	97.40%	IP55	IC411自冷风扇
降两个机座号	JPM315M15-450	8	450	380	100	788.63	Y	2865.00	1500	97.40%	IP55	IC411自冷风扇
降两个机座号	JPM315L15-500	8	500	380	100	876.25	Y	3183.33	1500	97.40%	IP55	IC411自冷风扇
降两个机座号	JPM315L15-560	8	560	380	100	981.40	Y	3565.33	1500	97.40%	IP55	IC411自冷风扇
降两个机座号	JPM315L15-630	8	630	380	100	1104.08	Y	4011.00	1500	97.40%	IP55	IC411自冷风扇
降两个机座号	JPM355M15-710	8	710	380	100	1244	Y	4520	1500	97.40%	IP55	IC411自冷风扇
降两个机座号	JPM355M15-800	8	800	380	100	1401	Y	5093	1500	97.40%	IP55	IC411自冷风扇
1000r/min永磁变频调速电机目录效率标准按照永磁1级能效 1000r/min permanent magnet frequency conversion speed control motor list motor efficiency comply with level 1 of standard efficiency of JPM motor												
降两个机座号	JPM80M10-1.5	6	1.5	380	50	2.67	Y	14.33	1000	89.90%	IP55	IC411自冷风扇
降两个机座号	JPM90L10-2.2	6	2.2	380	50	3.87	Y	21.01	1000	90.90%	IP55	IC411自冷风扇
降两个机座号	JPM100L10-3	6	3	380	50	5.21	Y	28.7	1000	91.80%	IP55	IC411自冷风扇
降两个机座号	JPM100L10-4	6	4	380	50	6.95	Y	38.2	1000	92.7%	IP55	IC411自冷风扇
降两个机座号	JPM100L10-5.5	6	5.5	380	50	9.55	Y	52.5	1000	93.4%	IP55	IC411自冷风扇
降两个机座号	JPM112M10-7.5	6	7.5	380	50	13.02	Y	71.6	1000	94%	IP55	IC411自冷风扇
降两个机座号	JPM112M10-11	6	11	380	50	19.10	Y	105.1	1000	94.5%	IP55	IC411自冷风扇
降两个机座号	JPM132M10-15	6	15	380	50	26.05	Y	143.3	1000	94.9%	IP55	IC411自冷风扇
降两个机座号	JPM160L10-18.5	6	18.5	380	50	32.13	Y	176.7	1000	95.30%	IP55	IC411自冷风扇
降两个机座号	JPM160L10-22	6	22	380	50	38.20	Y	210.1	1000	95.60%	IP55	IC411自冷风扇
降两个机座号	JPM180L10-30	8	30	380	66.7	52.10	Y	286.5	1000	95.80%	IP55	IC411自冷风扇
降两个机座号	JPM200L10-37	8	37	380	66.7	64.25	Y	353.4	1000	96.00%	IP55	IC411自冷风扇
降两个机座号	JPM200L10-45	8	45	380	66.7	78.14	Y	429.8	1000	96.20%	IP55	IC411自冷风扇
降两个机座号	JPM225S10-45	8	45	380	66.7	78.14	Y	429.8	1000	96.20%	IP55	IC411自冷风扇
降两个机座号	JPM225M10-55	8	55	380	66.7	95.51	Y	525.3	1000	96.30%	IP55	IC411自冷风扇
降两个机座号	JPM250M10-75	8	75	380	66.7	130.24	Y	716.3	1000	96.40%	IP55	IC411自冷风扇
降两个机座号	JPM250M10-90	8	90	380	66.7	156.29	Y	859.5	1000	96.50%	IP55	IC411自冷风扇
降两个机座号	JPM250M10-110	8	110	380	66.7	191.02	Y	1050.5	1000	96.60%	IP55	IC411自冷风扇
降两个机座号	JPM250M10-132	8	132	380	66.7	229.22	Y	1260.6	1000	96.80%	IP55	IC411自冷风扇
降两个机座号	JPM280M10-160	8	160	380	66.7	277.80	Y	1528.0	1000	96.90%	IP55	IC411自冷风扇
降两个机座号	JPM280M10-185	8	185	380	66.7	322.00	Y	1766.0	1000	97.00%	IP55	IC411自冷风扇
降两个机座号	JPM280M10-200	8	200	380	66.7	347.00	Y	1910.0	1000	97.00%	IP55	IC411自冷风扇
降两个机座号	JPM280M10-220	8	220	380	66.7	381.70	Y	2101.00	1000	97.00%	IP55	IC411自冷风扇

技术数据 Technical Data

类型 Type	电机型号 Type	级数 Pole	额定 功率 Output (kW)	额定 电压 Voltage (V)	频率 (Hz)	额定 电流 Current (A)	接法 Start type	额定 扭矩 (Nm)	额定转速 Rated Speed (r/min)	效率 Efficiency (%)	防护 等级 IP	冷却方式 Cooling mode
1000r/min永磁变频调速电机目录效率标准按照永磁1级能效 1000r/min permanent magnet frequency conversion speed control motor list motor efficiency comply with level 1 of standard efficiency of JPM motor												
降两个机座号	JPM280M10-250	8	250	380	66.7	434.00	Y	2387.0	1000	97.00%	IP55	IC411自冷风扇
降两个机座号	JPM280M10-280	8	280	380	66.7	486.00	Y	2674.0	1000	97.00%	IP55	IC411自冷风扇
降两个机座号	JPM315M10-315	8	315	380	66.7	546.00	Y	3008.0	1000	97.00%	IP55	IC411自冷风扇
降两个机座号	JPM315M10-355	8	355	380	66.7	616.00	Y	3390.0	1000	97.00%	IP55	IC411自冷风扇
降两个机座号	JPM315M10-400	8	400	380	66.7	694.08	Y	3820.00	1000	97.00%	IP55	IC411自冷风扇
降两个机座号	JPM315M10-450	8	450	380	66.7	780.85	Y	4297.50	1000	97.00%	IP55	IC411自冷风扇
降两个机座号	JPM315M10-500	8	500	380	66.7	868.00	Y	4775.0	1000	97.00%	IP55	IC411自冷风扇
降两个机座号	JPM315M10-560	8	560	380	66.7	972.00	Y	5348.0	1000	97.00%	IP55	IC411自冷风扇
降两个机座号	JPM355M10-630	8	630	380	66.7	1093.50	Y	6016.0	1000	97.00%	IP55	IC411自冷风扇
降两个机座号	JPM355M10-710	8	710	380	66.7	1232.36	Y	6780.0	1000	97.00%	IP55	IC411自冷风扇
降两个机座号	JPM355M10-800	8	800	380	66.7	1388.57	Y	7640.0	1000	97.00%	IP55	IC411自冷风扇
750r/min永磁变频调速电机目录效率标准按照永磁1级能效 750r/min permanent magnet frequency conversion speed control motor list motor efficiency comply with level 1 of standard efficiency of JPM motor												
降两个机座号	JPM80M7.5-0.75	6	0.75	380	37.5	1.43	Y	9.6	750	83.85%	IP55	IC411自冷风扇
降两个机座号	JPM80M7.5-1.1	6	1.1	380	37.5	2.06	Y	14.0	750	84.85%	IP55	IC411自冷风扇
降两个机座号	JPM90L7.5-1.5	6	1.5	380	37.5	2.06	Y	19.1	750	86.00%	IP55	IC411自冷风扇
降两个机座号	JPM100L7.5-2.2	6	2.2	380	37.5	3.82	Y	28.0	750	87.20%	IP55	IC411自冷风扇
降两个机座号	JPM100L7.5-3	6	3	380	37.5	5.21	Y	38.2	750	88.10%	IP55	IC411自冷风扇
降两个机座号	JPM112M7.5-4	6	4	380	37.5	6.95	Y	50.9	750	88.95%	IP55	IC411自冷风扇
降两个机座号	JPM112M7.5-5.5	6	5.5	380	37.5	9.55	Y	70.0	750	90.15%	IP55	IC411自冷风扇
降两个机座号	JPM112M7.5-7.5	6	7.5	380	37.5	13.02	Y	95.5	750	90.90%	IP55	IC411自冷风扇
降两个机座号	JPM132S7.5-11	6	11	380	37.5	19.10	Y	140.1	750	91.45%	IP55	IC411自冷风扇
降两个机座号	JPM160L7.5-15	6	15	380	37.5	26.05	Y	191.0	750	92.70%	IP55	IC411自冷风扇
降两个机座号	JPM180L7.5-18.5	8	18.5	380	50	32.13	Y	235.6	750	93.25%	IP55	IC411自冷风扇
降两个机座号	JPM180L7.5-22	8	22	380	50	38.20	Y	280.1	750	94.00%	IP55	IC411自冷风扇
降两个机座号	JPM200L7.5-30	8	30	380	50	52.10	Y	382.0	750	94.45%	IP55	IC411自冷风扇
降两个机座号	JPM225M7.5-37	8	37	380	50	64.25	Y	471.1	750	94.70%	IP55	IC411自冷风扇
降两个机座号	JPM225M7.5-45	8	45	380	50	78.14	Y	573.0	750	94.95%	IP55	IC411自冷风扇
降两个机座号	JPM250M7.5-55	8	55	380	50	95.51	Y	700.3	750	95.20%	IP55	IC411自冷风扇
降两个机座号	JPM250M7.5-75	8	75	380	50	130.24	Y	955.0	750	95.40%	IP55	IC411自冷风扇
降两个机座号	JPM250M7.5-90	8	90	380	50	156.29	Y	1146.0	750	95.55%	IP55	IC411自冷风扇
降两个机座号	JPM250M7.5-110	8	110	380	50	191.02	Y	1400.0	750	95.60%	IP55	IC411自冷风扇
降两个机座号	JPM280M7.5-132	8	132	380	50	229.00	Y	1680.0	750	96.90%	IP55	IC411自冷风扇
降两个机座号	JPM280M7.5-160	8	160	380	50	278.00	Y	2037.0	750	97.10%	IP55	IC411自冷风扇
降两个机座号	JPM280M7.5-185	8	185	380	50	322.00	Y	2355.7	750	97.20%	IP55	IC411自冷风扇
降两个机座号	JPM280M7.5-200	8	200	380	50	347.00	Y	2546.0	750	97.50%	IP55	IC411自冷风扇
降两个机座号	JPM315M7.5-250	8	250	380	50	434.00	Y	3183.0	750	97.50%	IP55	IC411自冷风扇
降两个机座号	JPM315M7.5-280	8	280	380	50	486.08	Y	3565.33	750	97.50%	IP55	IC411自冷风扇
降两个机座号	JPM315M7.5-315	8	315	380	50	547.00	Y	4011.0	750	97.50%	IP55	IC411自冷风扇
降两个机座号	JPM315M7.5-375	8	375	380	50	651.00	Y	4775.0	750	97.50%	IP55	IC411自冷风扇
降两个机座号	JPM315M7.5-400	8	400	380	50	694.00	Y	5093.0	750	97.50%	IP55	IC411自冷风扇
降两个机座号	JPM355M7.5-450	8	450	380	50	782.00	Y	5730.0	750	97.50%	IP55	IC411自冷风扇
降两个机座号	JPM355M7.5-500	8	500	380	50	868.00	Y	6366.0	750	97.50%	IP55	IC411自冷风扇
降两个机座号	JPM355M7.5-560	8	560	380	50	972.00	Y	7130.0	750	97.50%	IP55	IC411自冷风扇
降两个机座号	JPM355M7.5-630	8	630	380	50	1094.00	Y	8022.0	750	97.50%	IP55	IC411自冷风扇

注: 若有特殊要求, 可按用户需求提供。 Please contact us with your requirement.